

Solar PV Array Ćuk Converter Fed Single Phase Induction Motor Drives for Water Pumping

Priyvrat Vats¹ and Yash Pal²

^{1,2}NIT Kurukshetra, Kurukshetra

E-mail: ¹priyvrat.107024@gmail.com, ²yash_pal1971@yahoo.com

Abstract—This paper deals with a water pumping system which is powered by PV (Photo Voltaic) cell. A Ćuk Converter topology is being used between solar panel and the PWM inverter. The DC link voltage is maintained constant by controlling the duty cycle of the high level Ćuk Converter. Water pump is being driven by single phase induction machine which is fed with the output of single phase PWM inverter. Performance of proposed system is obtained under variable solar irradiation. The water pumping system is modelled in MATLAB/ SIMULINK environment using the Sim Power System and SIMSCAPE tool boxes. The performance of the system is analyzed with simulation.

1. INTRODUCTION

Technological advancement of present power sector has been consistently moving towards minimization of carbon emission. Renewable energy resources are major contributors of this advancement. Solar photovoltaic (SPV) cell technology has played a pivotal role in integrating the solar energy to the electrical grid. Large SPV power plants are integrated to the electrical grid in present times. SPV technology is a promising substitute to the thermal based generation. Its benefits include no gaseous emissions, no operation cost involved, less maintenance and one time investment. With advancement in the semiconductor technology the efficiency of the SPV modules have increased up to 20%. Moreover, the concentrated PV cell can achieve an efficiency of about 43%.

Solar PV based water pumping system are gaining popularity nowadays especially in developing countries. In agricultural economies such as India, water pumping is of prime importance. Remote and rural areas devoid of uninterrupted electrical supply face serious shortage of water for irrigation and drinking. Standalone SPV array fed water pumps are quite useful for such areas.

This paper presents a standalone Solar PV based Induction Motor drive for water pumping system. In the proposed control scheme duty cycle of the high Ćuk converter is controlled to maintain the DC link voltage at required level. Induction machine has been controlled using field oriented

vector control scheme. The speed of the Induction Motor drive is a function of solar irradiation. The performance of the developed PV system has been analyzed using simulation.

The IGBT with antiparallel diode base single phase VSI is used and its switching is given according to V/F control based SPWM control. V/F control also minimize inrush current which is very high in starting. This paper is divided in five section. Section 2 deals the proposed system configuration and its design criteria in Section 3 control strategy including INC MPPT algorithm Section 4 results and discussion and conclusion in Section 5.

2. PROPOSED SYSTEM CONFIGURATION DESIGN

Fig. 1 shows the system configuration of Solar based water pump system with Ćuk Converter. A 2HP Single Phase Induction Machine is used to drive the water pump system. The Solar energy is converted to electrical energy using PV cells. A high level Ćuk Converter topology has been used to regulate output voltage of PV array and is being controlled to maintain constant DC link voltage.

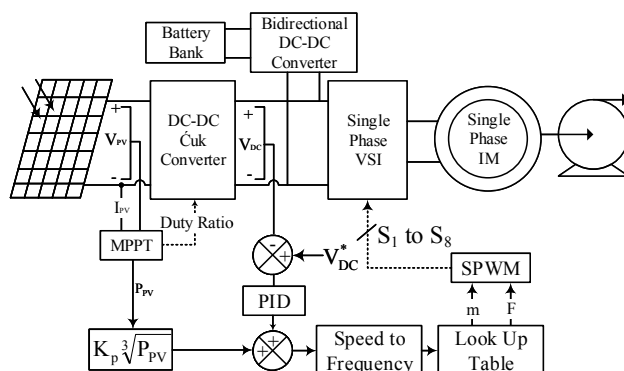

Fig. 1: Proposed Model

To facilitate variable speed operation for achieving MPPT, the induction machine has been driven by PWM

inverter. Constant V/F control has been used for controlling the induction machine. The high level Ćuk Converter controls the DC link voltage of the PV system. The speed of the Induction Motor drive has been controlled by the PWM inverter according to the MPPT scheme.

2.1 PV Array Design

	Single Module SPV Array	Complete SPV Array Module
Power at MPP (P_{mp})	160.2W	1602W
Voltage at MPP (V_{mp})	35.6V	356V
Current at MPP (I_{mp})	4.5A	4.5A
Open Circuit Voltage (V_{oc})	43.8V	438V
Short Circuit Current (I_{sc})	5A	5A
Fill Factor	0.7315	0.7315
No. of Series Module (N_s)	10	
No. of Parallel Module (N_p)	1	

2.2 DC Link Voltage (Vdc)

The required DC link voltage is estimated as

$$V_{dc} = \sqrt{2} \times V_{rms} = \sqrt{2} \times 230 = 325.26V \tag{1}$$

Hence, DC link voltage is chosen to be 350V.

2.3 Design of Ćuk Converter

$$D = \frac{V_{dc}}{V_{dc} + V_{mp}} = \frac{350}{350 + 356} = 0.4957 \tag{2}$$

$$L_1 = L_2 = \frac{V_{mp} \times D}{\Delta I_L \times f_s} = \frac{356 \times 0.4957}{0.2 \times 5 \times 5000} = 35.29mH \tag{3}$$

$$C_1 = \frac{I_{mp} \times (1 - D)}{\Delta V \times f_s} \tag{4}$$

$$C_1 = \frac{4.5 \times (1 - 0.4957)}{325.26 \times 0.25 \times 5000} = 5.582\mu F$$

$$C_2 = \frac{I_{DC}}{6 \times \omega \times \Delta V_{DC}} \tag{5}$$

$$C_2 = \frac{1602 / 350}{6 \times \frac{2 \times \pi \times 1500 \times 4}{120} \times 0.08 \times 350} = 867\mu F$$

Parameter	Data Calculated	Data Selected
V_{dc}	325.26V	350V
D	0.4957	0.4957
L_1	35.29mH	40mH
L_2	35.29mH	40mH
C_1	5.582μF	10μF
C_2	867μF	900μF

2.4 Design of Bidirectional DC-DC Converter and Battery

$$D_{buck} = \frac{V_b}{V_{dc}} = \frac{12}{350} = 0.0348 \tag{6}$$

$$D_{boost} = \frac{V_{dc} - V_b}{V_{dc}} = \frac{350 - 12}{350} = 0.9657 \tag{7}$$

Parameter	Data Selected
D_{buck}	0.0348
D_{boost}	0.4914
$L_{bidirectional}$	2.3mH
V_b	12V
AHr Capacity of Battery	375Ahr

2.5 Design of Water Pump

$$T_L = K_p \times \omega_r^2 \tag{8}$$

$$K_p = \frac{9.94}{(2 \times \pi \times 24)^2} = 0.00043712Nm / (rad / sec)^2$$

Where, D is duty ratio, C is DC link capacitor, T_L is load torque, K_p is pump constant, ω_r is speed of IM.

3. CONTROL APPROACH FOR PROPOSED SYSTEM

The block diagram of the proposed control scheme is shown in the Fig. 1. The PV system is controlled through two individual control schemes. One control loop for Ćuk Converter controls the DC link voltage based on INC (Incremental Conductance) MPPT algorithm. The other control scheme for the VSI to operate in constant V/F mode regulates the speed of the drive under change in solar irradiation.

3.1 INC MPPT Algorithm

The MPPT approach based on an INC is adopted to track an optimum point on the current–voltage (I_{pv} - V_{pv}) characteristics of the solar PV array. This method explores that the power slope of a PV array characteristics is null at MPP ($dP_{pv}/dV_{pv} = 0$), negative at right of MPP and positive at left of MPP. Therefore, an optimum operating point is derived based on an INC. INC algorithm flow chart is given in fig.2.

3.2 V/F Control of Induction Motor Drive

For constant flux operation of IM V/F should be constant throughout the operation. The operating speed is given by input power according to mentioned relation. This will generate modulation index and frequency reference for V/F control. The integration of speed gives

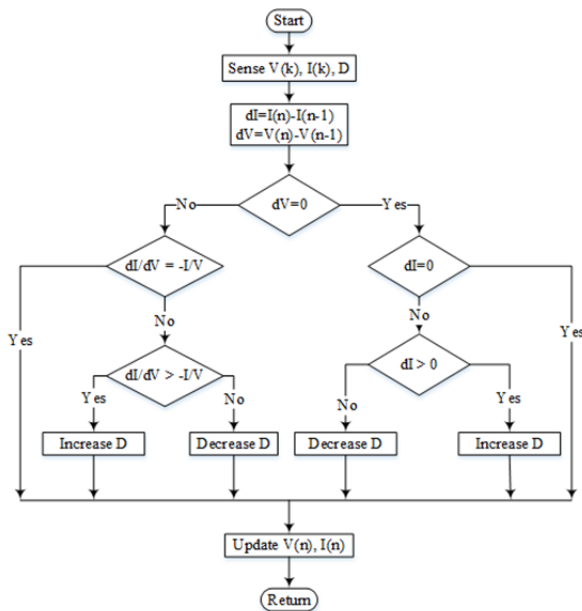

Fig. 2. INC MPPT Algorithm Flow Chart

Φ which control the frequency of reference sinusoidal wave.

$$\phi = \int \omega^* dt \tag{8}$$

$$V^* = a \times \sin(\phi) \tag{9}$$

Where, 'a' is modulation index.

To generate reference speed following step is taken

The DC link voltage error

$$V_r = V_{dc}^* - V_{dc} \tag{10}$$

This error voltage is passed to PID controller which gives speed error as follows

$$\omega_{r(n)} = \omega_{r(n-1)} + K_p \times \{V_{r(n)} - V_{r(n-1)}\} + K_I \times V_{r(n)} \tag{11}$$

Pump speed is given as $\omega_{pump} = K_p \sqrt[3]{P_{pv}}$

Reference speed is given as $\omega^* = \omega_{pump} + \omega_r$

Where, ω^* is reference speed of pump and ω_r is error speed.

4. RESULT AND DISCUSSION

The simulation result of the proposed system is given here. The simulation is carried out in Matlab/Simulink 2016a environment for 3 sec simulation time with varying irradiance value from 1000W/m² to 600W/m² and temp 350C. The

performance of system is shown below in different figures with capacitor start induction machine.

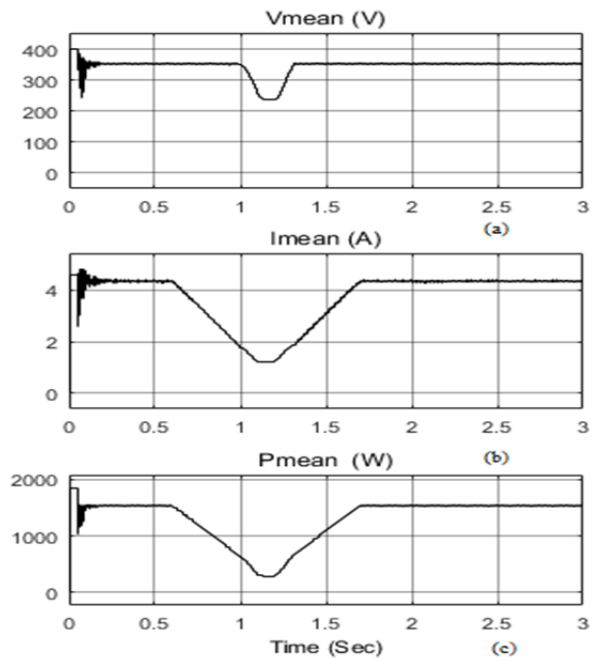

Fig. 3. PV Performance (a) PV Voltage (b) PV Current (c) PV Power Generated

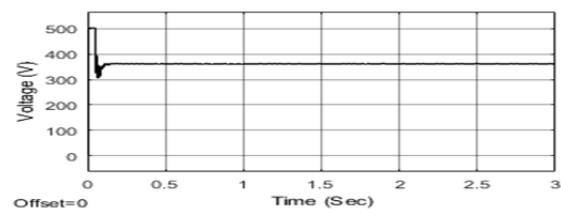

Fig. 4. Ćuk Converter Output Voltage

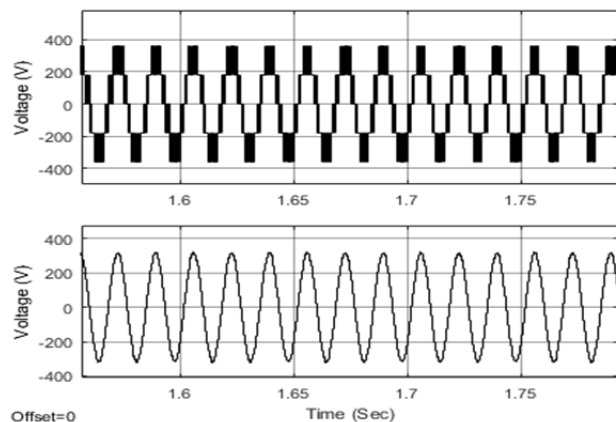

Fig. 5. VSI Output Voltage

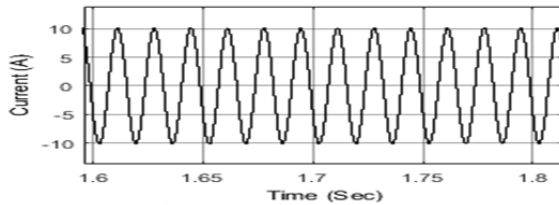

Fig. 6. Capacitor Start Single Phase IM Steady State Current

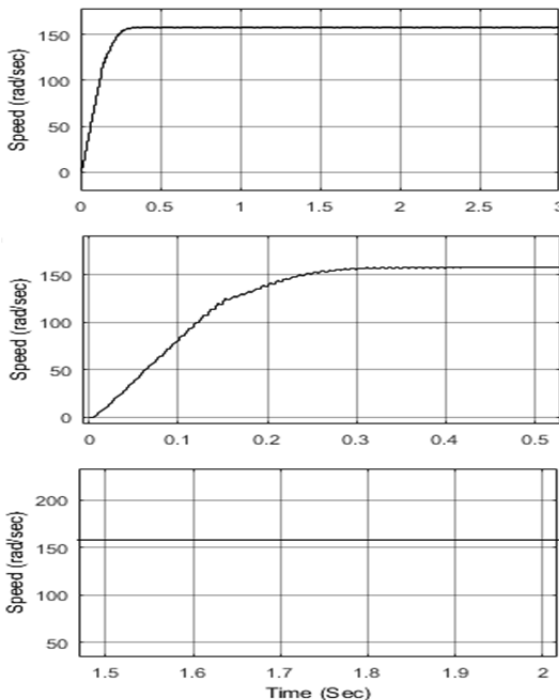

Fig. 7: Single Phase Capacitor Start IM Performance

5. CONCLUSION

All simulated result of capacitor start IM is shown in section 4 and it gives as per theoretical conclusion. A comprehensive analysis of capacitor start IM carried out and simulated result gives desired solution as per theoretical conclusion. The simulation result for capacitor start machine show 0.6% THD in current and 1.90% THD in voltage which is in permissible limit as per IEEE-519 standard. The starting performance of capacitor start induction machine is as per theoretical analysis. So, this paper conclude that SPV array Ćuk fed single phase capacitor start IM can work very well in all conditions and it can utilize in agriculture purpose.

REFERENCES

[1] M. Sreejeth, M. Singh and P. Kumar, "Efficiency optimization of vector controlled induction motor drive," IECON 2012 - 38th Annual Conference on IEEE Industrial Electronics Society, Montreal, QC, 2012, pp. 1758-1763.

- [2] U. Sharma, S. Kumar and B. Singh, "Solar array fed water pumping system using induction motor drive," 2016 IEEE 1st International Conference on Power Electronics, Intelligent Control and Energy Systems (ICPEICES), Delhi, 2016, pp. 1-6.
- [3] S. Dangeam and V. Kinnares, "A direct torque control for three-leg voltage source inverter fed asymmetrical single-phase induction motor," 2015 18th International Conference on Electrical Machines and Systems (ICEMS), Pattaya, 2015, pp. 1569-1574.
- [4] B. Singh, S. Shukla, A. Chandra and K. Al-Haddad, "Loss minimization of two stage solar powered speed sensorless vector controlled induction motor drive for water pumping," IECON 2016 - 42nd Annual Conference of the IEEE Industrial Electronics Society, Florence, 2016, pp. 1942-1947.
- [5] R. Kumar and B. Singh, "Solar PV powered BLDC motor drive for water pumping using Cuk converter," in IET Electric Power Applications, vol. 11, no. 2, pp. 222-232, 2 2017.
- [6] V. Narayana, A. Kumar Mishra and B. Singh, "Development of low-cost PV array-fed SRM drive-based water pumping system utilising CSC converter," in IET Power Electronics, vol. 10, no. 2, pp. 156-168, 2 10 2017.
- [7] B. Singh and R. Kumar, "Simple brushless DC motor drive for solar photovoltaic array fed water pumping system," in IET Power Electronics, vol. 9, no. 7, pp. 1487-1495, 6 8 2016.
- [8] R. Kumar and B. Singh, "BLDC Motor-Driven Solar PV Array-Fed Water Pumping System Employing Zeta Converter," in IEEE Transactions on Industry Applications, vol. 52, no. 3, pp. 2315-2322, May-June 2016.
- [9] B. Singh and R. Kumar, "Solar PV array fed brushless DC motor driven water pump," 2016 IEEE 6th International Conference on Power Systems (ICPS), New Delhi, 2016, pp. 1-5.
- [10] R. Kumar and B. Singh, "Solar PV-battery based hybrid water pumping system using BLDC motor drive," 2016 IEEE 1st International Conference on Power Electronics, Intelligent Control and Energy Systems (ICPEICES), Delhi, 2016, pp. 1-6.
- [11] A. K. Mishra and B. Singh, "Solar energized SRM driven water pumping utilizing modified Landsman converter," 2016 IEEE 1st International Conference on Power Electronics, Intelligent Control and Energy Systems (ICPEICES), Delhi, 2016, pp. 1-6.
- [12] S. Shukla and B. Singh, "Single stage SPV array fed speed sensorless vector control of induction motor drive for water pumping," 2016 IEEE 1st International Conference on Power Electronics, Intelligent Control and Energy Systems (ICPEICES), Delhi, 2016, pp. 1-6.
- [13] B. Singh and R. Kumar, "Solar photovoltaic array fed water pump driven by brushless DC motor using Landsman converter," in IET Renewable Power Generation, vol. 10, no. 4, pp. 474-484, 4 2016.
- [14] B. Singh, S. Dwivedi, U. Sharma and C. Jain, "Solar PV array fed direct torque controlled induction motor drive for water pumping," 2015 Annual IEEE India Conference (INDICON), New Delhi, 2015, pp. 1-6.
- [15] R. Kumar and B. Singh, "BLDC motor driven water pump fed by solar photovoltaic array using boost converter," 2015 Annual IEEE India Conference (INDICON), New Delhi, 2015, pp. 1-6.
- [16] R. Kumar and B. Singh, "Solar photovoltaic array fed Luo converter based BLDC motor driven water pumping system," 2014 9th International Conference on Industrial and Information Systems (ICIIS), Gwalior, 2014, pp. 1-5.